

Owner's Manual

Safety, Installation, Maintenance, and Operation

Model SHD-138



American Eagle, Inc.
740 N. State Street
PO Box 169
Garner, IA 50438
800-392-3015
Fax: 641-923-9099
www.americaneagleacc.com

Introduction

American Eagle Compressors are designed to provide safe and dependable service for a variety of operations. With proper use and maintenance, American Eagle Compressors will operate at peak performance for many years.

This manual contains information vital to the safe use and efficient operation of this unit. Following the information provided within this manual can ensure the longevity of the compressor. Carefully read and study the operator's manual before using the unit. Failure to adhere to the instructions could result in property damage or even serious bodily injury to the operator or others close to the compressor.

A copy of this manual is provided with every compressor and shall remain with the compressor at all times. Information contained within this manual does not cover all maintenance, operating, or repair instructions pertinent to all possible situations. This manual is not binding. American Eagle reserves the right to change, at any time, any or all of the items, components, and parts deemed

necessary for product improvement or commercial/production purposes. This right is kept with no requirement or obligation for immediate mandatory updating of this manual.

This product manual is not intended as a training manual for beginners or unskilled operators. This manual offers guidelines for correct and safe usage of the compressor, maintenance, and troubleshooting. If more information is required or technical assistance is needed, please contact AE Technical Support.

Some sections of this manual contain information pertaining to all American Eagle manufactured compressors and may or may not apply to your specific model.

If this manual becomes damaged, misplaced, or unreadable at any point, or if you feel that any part of this manual is unclear or incorrect, please contact AE Technical Support at 800-321-3741 or email at service@americaneagleacc.com

**For Technical Questions, Information, Parts, or Warranty, Call Toll-Free at
800-321-3741**

Hours: Monday - Friday, 8:00 a.m. - 5:00 p.m. CST

Or email at the following addresses:

Technical Questions, and Information

service@americaneagleacc.com

Order Parts

parts@americaneagleacc.com

Warranty Information

warranty@americaneagleacc.com

Table of Contents

Safety	Page 3
Specifications	Page 4
Operation	Page 5
Head Unloading System	Page 6
Maintenance	Page 7
Installation	Page 8
Assembly Drawings	Page 12
Replacement Parts	Page 16
Troubleshooting	Page 17
Warranty	Page 19

Safety

This manual contains vital information for the safe use and efficient operation of this unit. Carefully read the operators manual before starting the unit. Failure to adhere to the instructions could result in serious bodily injury or property damage.

The SHD-138 Hydraulic Air Compressor will provide safe and dependable service if operated according to instructions. Read and understand the safety precautions given in this manual and on the decals attached to the shields. Failure to do so can result in personal injury or equipment damage.

Operators and maintenance personnel must always comply with the safety precautions. These precautions are given here for your safety. Review them carefully before operating the compressor and before performing maintenance or repairs.

Supervising personnel should develop additional precautions relating to the specific work area and local safety regulations.

Precautions

Always wear safety equipment such as goggles, ear plugs and head protection at all times when operating the compressor.

Do not inspect or clean the compressor while the hydraulic power source is connected. Accidental engagement of the tool can cause serious injury.

Before performing any maintenance on the compressor, place a warning tag on the hydraulic power source or disconnect the hoses from the compressor motor to prevent accidental startup of the compressor.

Always connect hoses to the compressor before energizing the hydraulic power source. Be sure

all hose connections are tight, both air and hydraulic.

Establish a training program for all operators to ensure safe operation.

Do not operate the compressor unless thoroughly trained or under the supervision of an instructor.

Do not operate the compressor if it is damaged, improperly adjusted or not completely or properly assembled.

Never operate the compressor with any of the guards removed.

Do not attempt to adjust or disable the compressors air pressure relief valve. This valve limits the air pressure to 175 PSI.

The surface of the air compressor and the plumbing between the compressor and the cooler may reach temperatures above 150 degrees. Touching these surfaces during operation can cause burns.

The air taken in by the air compressor must be free of flammable fumes and vapors.

Compressor speed should not exceed 1000 RPM.

Use and operate this air compressor only in full compliance with all pertinent O.S.H.A. requirements and all Federal, State and Local codes or requirements.

Specifications

Drive System Description

- | | |
|--|---|
| <ul style="list-style-type: none"> • 16 GPM Hydraulic System • 2500 PSI Pressure Relief Setting • Hydraulic Hose Plumbing • Belt drive w/Gates 3B90 belt | <ul style="list-style-type: none"> • 2000 PSI System Pressure • 12 VDC Solenoid Control Valve • 6061 Aluminum Manifold • Air Pressure Control Valve |
|--|---|

Compressor System Description

- | | |
|--|---|
| <ul style="list-style-type: none"> • Cast Iron Crankcase Casting • Gasket-free Integrated Cylinder/Head • Precision Balanced Flywheel • Large Diameter Finned Inner Cooling Tubing • Positive Acting Centrifugal Head Unloaders | <ul style="list-style-type: none"> • Tapered Roller Main Bearings • Heavy Ductile Iron Crankshaft • Pressure Relief Valves in Interstage and Discharge • Pressure Lubricated System • Preset Pilot Control Valve |
|--|---|

General Information

- | | |
|--|---|
| <ul style="list-style-type: none"> • Model: • Weight: • Delivery: • Maximum Working Pressure: • Electrical: • Crankcase Oil Capacity: • Cylinders: • Maximum Compressor Speed: | <p>Champion R40
 800 lbs. (dry)
 60 SCFM @ 175 PSI
 175 PSI
 12 VDC @ 10 amp
 4 Quart
 Two Cylinder(Dual Stage)
 1000 RPM</p> |
|--|---|

Operation

Each compressor is bench tested under load at the factory to ensure proper break-in and operation. While it is not necessary to follow any break-in procedure, the following checks should be made before putting the unit into service and periodically during use.

Before Start-Up

Inspect unit for any visible signs of damage.

Check the oil level in the compressor with the dipstick on the unit. If oil is needed, use American Eagle synthetic compressor oil (P/N C0087) or an equivalent synthetic oil. **Note: There may be oil left in the crankcase from the factory bench test. Overfilling may cause the compressor to back blow oil. Always check the oil level and fill to the designated marking on the dipstick before putting the unit into service.**

Check hoses (air and hydraulic) for weak or worn condition and make sure that all connections are secure.

Check the air intake filters on each head to make certain that they are clean and unobstructed. Dirty air filters are a possible cause of reduced air output.

General Information

To use the compressor, start the vehicle engine and engage the hydraulic system. The compressor can now be activated using the compressor switch. This energizes the hydraulic solenoid sending oil to the hydraulic drive motor and starts the compressor. Through the air pressure switch and pilot valve, the system will now function automatically. Once engaged, adjust the engine speed control to ensure that the compressor speed does not exceed 1000 RPM under load. Adjustment instructions are provided with the speed control unit.

Air Pilot Valve Operation (Head Unloading System)

When the hydraulic system is engaged the compressor will pump air into the receiver until the pressure reaches 175 psi. At this time the air pilot valve senses the pressure in the receiver and engages an intake valve hold-open mechanism. The compressor will run free until the pressure in the receiver falls below 145 psi and the air pressure valve disengages the intake valve hold-open mechanism to allow the

compressor to pump air. See head unloading system for detailed views and adjustment instructions the following page.

Operating Notes

This reciprocating compressor must not be used for breathing air. To do so will cause serious injury whether air is supplied direct from the compressor source or to breathing tanks for later use. Any and all liabilities for damage or loss due to injuries, death and/or property damage, including consequential damages stemming from the use of this compressor to supply breathing air will be disclaimed by the manufacturer.

The use of this compressor as a booster pump and/or to compress a medium other than atmospheric air is strictly non-approved and can result in equipment damage and/or injury. Non-approved uses will also void the warranty.

Never use plastic pipe or improperly rated metal pipe. Improper piping materials can burst and cause injury or property damage.

Head Unloading System

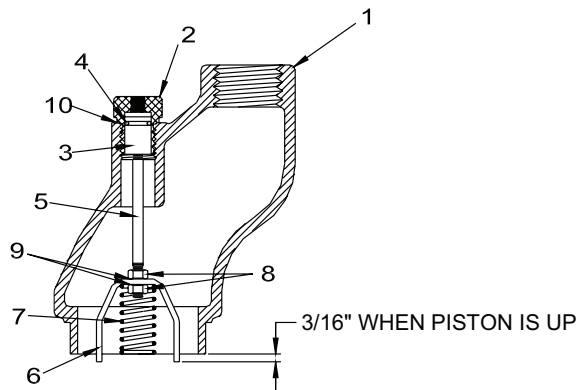

CAUTION

When re-installing head unloader the actuating claw (Ref. No. 6) protrudes 3/16" below the bottom of the manifold (Ref. No. 1) as shown. Claw must be position so that it will enter three slots in the compressor valve. Failure to follow this procedure will result in an inoperative head unloader.

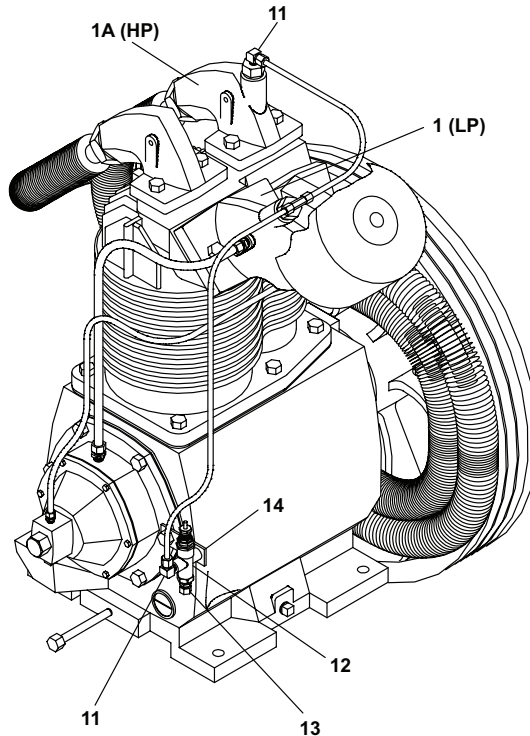

ITEM	PART	DESCRIPTION	QTY.	ITEM	PART	DESCRIPTION	QTY.
1	26804	LOW PRESSURE INTAKE MANIFOLD R70	2	9	0521	WASHER 0.25 LOCK	12
1A	26807	HIGH PRESSURE INTAKE MANIFOLD R70	2	10	7493	GASKET UNLOADER VALVE R70	2
2	7481	CYLINDER UNLOADER VALVE R70	4	11	17252	COMPRESSION FITTING	2
3	26812	UNLOADER PISTON R70	4	12	C5568	UNLOADER VALVE CONRADER	1
4	7483	O'RING UNLOADER VALVE R70	4	13	7499	COMPRESSION FITTING R70	1
5	13924	PISTON ROD LP UNLOADER VALVE R70	2	14	C6064	U BOLT 0.25X1.25X2.25	1
5A	13925	PISTON ROD HP UNLOADER VALVE R70	2	---	13735	UNLOADER VALVE ASM LP R70	2
6	4567	CLAW UNLOADER VALVE LP R70	2	---	13736	UNLOADER VALVE ASM HP R70	2
6A	13921	CLAW UNLOADER VALVE HP R70	2				
7	13922	SPRING UNLOADER VALVE LP R70	2				
7A	13923	SPRING UNLOADER VALVE HP R70	2				
8	1056	NUT 0.25-28 HH	8				

Air Pilot Valve Adjustment

(See Air Pilot Valve Adjustment Detail)

High Pressure Adjustment: Proceed with the following while the compressor is running.

- 1.) Loosen locknut (4) and back off several turns. Do not turn differential adjuster (3).
- 2.) Check reading on the tank pressure gauge. Set the compressor maximum pressure at 175 psi. Over pressurizing compressor will cause damage and void warranty. Turn threaded cap (1) clockwise to increase pressure or counterclockwise to decrease pressure.
- 3.) After pressure is set, tighten locknut
- 4.) Be careful not to move the threaded cap (1).

Differential Pressure Adjustment: Proceed with the following while the compressor is running.

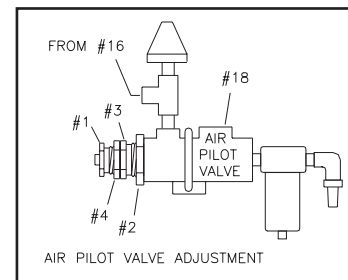

- 1.) Loosen locknut (2) and back off several turns.
- 2.) Check reading on the tank pressure gauge. Set the pressure to 30 psi differential (unload at 175 psi, reload at 145 psi). Turn nut (3) clockwise to increase differential pressure or counterclockwise to decrease differential pressure.
- 3.) After pressure is set, tighten locknut (2). Be careful not to move nut (3)

Maintenance

The following table is a list of routine maintenance items, including service intervals. Service intervals are listed as hours, days, or weeks, whichever occurs first. American Eagle recommends that these service intervals be followed. Before performing any maintenance function “Lock Out” or “Tag Out” all sources of power. Be sure all air pressure in unit is relieved. Failure to do so may result in injury or equipment damage.

Service Intervals				
Maintenance operation	Daily	Weekly	Monthly	Hourly
Drain air tanks	☑	☑	☑	
Check crankcase oil level	☑			
Check fittings and airlines	☑			
Check hydraulic fluid level	☑			
Inspect and clean air intake filters		☑		
Clean and operate safety valves		☑		
Clean cooling fins on radiator		☑		
Inspect check valve		☑		
Inspect and clean compressor valves			6	
Replace hydraulic filter			6	
Replace air filters			3	
Tighten all fittings and fasteners			3	
Check all electrical connections			3	
Inspect and clean air check valve				250
CHANGE CRANKCASE OIL (see footnote below)				

Under normal operating conditions, oil changes are required every 3 months. When operating in a dirty environment, change the oil more frequently as your particular operating condition dictates.

**USE AE SYNTHETIC COMPRESSOR OIL P/N C0087.
COMPRESSOR CRANKCASE CAPACITY IS 5 QUARTS.**

General preventative maintenance includes maintaining proper fluid level in both systems and the general cleanliness of the equipment. Proper fluids according to the specifications are required.

Installation

COMPONENT INSTALLATION

This section pertains to the installation of the air compressor, PTO, pump and other related items. The instructions are intended as a guide to assist you with particular installation. These instructions will provide only general information.

Pump Assembly:

The pump assembly may either be installed directly on the PTO or as an optional method, may be driven by a driveline from the PTO. Pump manufacturers provide specific installation information for their products and should be consulted if questions arise.

PTO Assembly:

Check with the PTO manufacturer representative for specific instructions regarding your particular make, model, and year of vehicle. As some trucks may require modification of the transmission cross member and the exhaust system, the manufacturer's instructions should be followed to insure proper installation of the PTO.

Compressor Assembly:

Prepare the mounting location of the compressor by locating and drilling four (4) holes, 9/16" diameter as per the mounting pattern of the air compressor base. Using four (4) 1/2" x 1.50 GR-5 cap screws, 1/2" flat washer, and 1/2" nyloc nut, secure the compressor in place. The compressor is air cooled, and must have a clean supply of cooling air to the fan with minimum restrictions. Adequate space must be provided for proper circulation of air.

Electrical Connections:

From the solenoid valve (located on the hydraulic manifold) there are two (2) wires, red and black, running to the compressor pressure switch. Connect the black wire to the vehicle frame or other suitable ground. The red wire mounts to the pressure switch as shown. Install

a toggle switch in a convenient location. Connect one terminal to the compressor pressure switch and the other terminal to a 12-volt power supply. Add a 20 amp fuse between the battery and switch. A third wire is required from the air compressor pressure switch when connecting the speed control into the system. (See drawing below)

Electric speed control:

An optional electric or electronic speed control must be used to maintain proper operating speed of the air compressor. The engine speed control will automatically increase from idle to a preset speed when engaged and decrease when disengaged. The electric speed control (American Eagle P/N C0873) is used on most gasoline engines. The electronic speed controls are used only on Ford 6.0 and 7.3L diesel engines. Proper installation instructions are provided with each system.

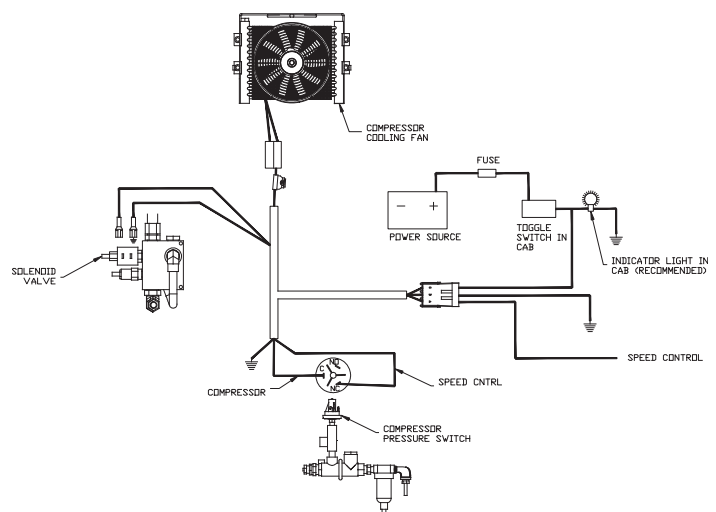

Component Installation Continued...

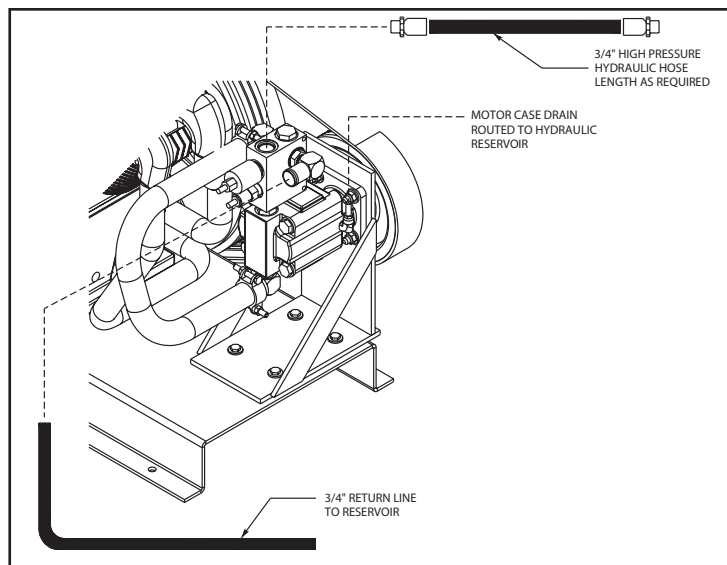

Hydraulic System:

Installed on the compressor is a valve block assembly that controls the flow to the hydraulic motor. To this block, a 3/4" high-pressure hose and a 3/4" return line must be attached. (See drawing above) Note: The case drain line from the hydraulic motor is also routed to the oil reservoir. American Eagle recommends a sufficient sized reservoir be provided which includes the proper suction and return filters. The cooler on the compressor is designed and sized to cool the air compressor efficiently. An auxiliary oil cooler is required when additional hydraulically operated equipment are added to the hydraulic system. Pressure on the return line exceeding 200 PSI can and will cause damage to the filter, cooler, and components of the compressor hydraulic system.

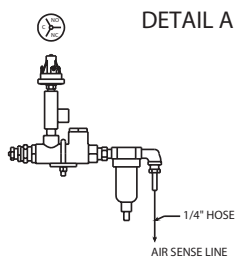
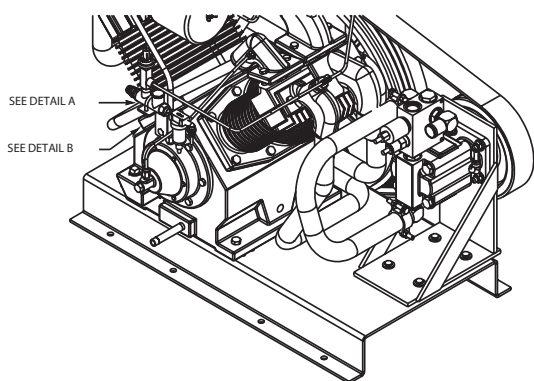

DETAIL B

CHECK VALVE MUST BE PLACED BETWEEN AIR DELIVERY LINE AND TANK

This detail diagram shows a check valve installed on an air delivery line. The check valve must be placed between the air delivery line and the tank.

Air System:

Two (2) airlines must be routed to the air tank for proper installation. The main airline is routed from the check valve to the air tank using a 3/4"(200psi) air hose. This is the main delivery line and should be free from all obstructions. A 1/4" line is routed from the air pressure valve to the air tank. This line senses the pressure in the tank and will engage and disengage the compressor automatically.

Typical Hydraulic Circuit for Single Stage Pump with Multiple Components

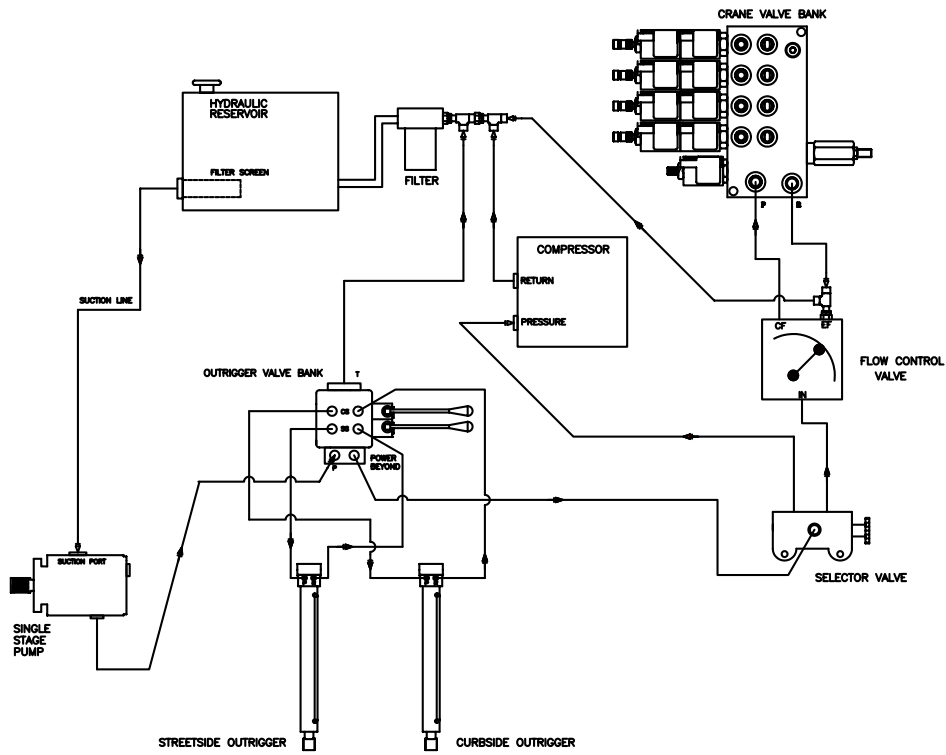

Typical Hydraulic Circuit for Tandem (Two Part) Pump with Multiple Components

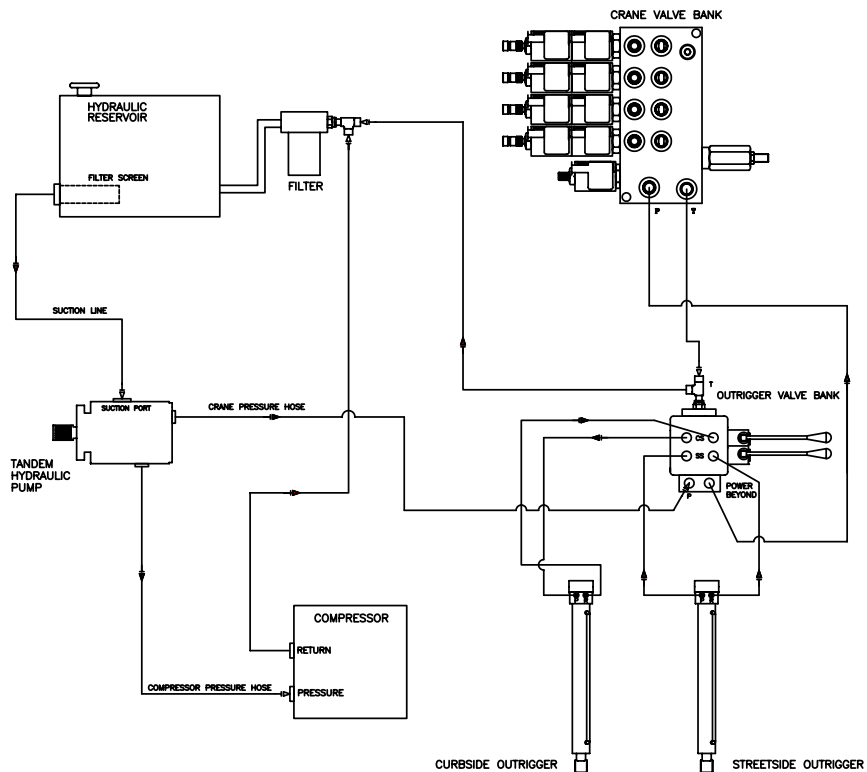

Typical Hydraulic Circuit for Compressor with Auxiliary Cooler

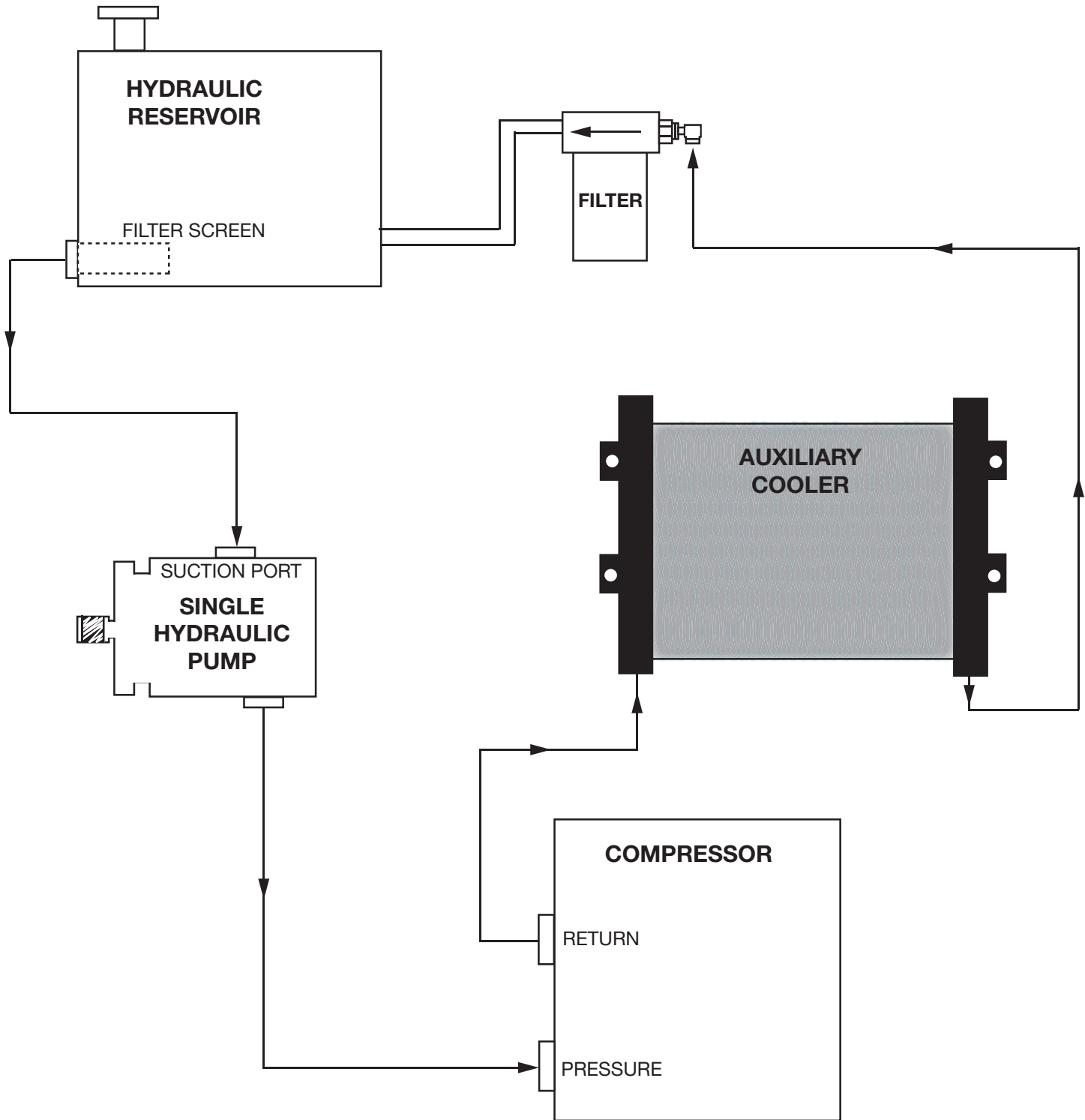

Assembly Drawings

Compressor Assembly

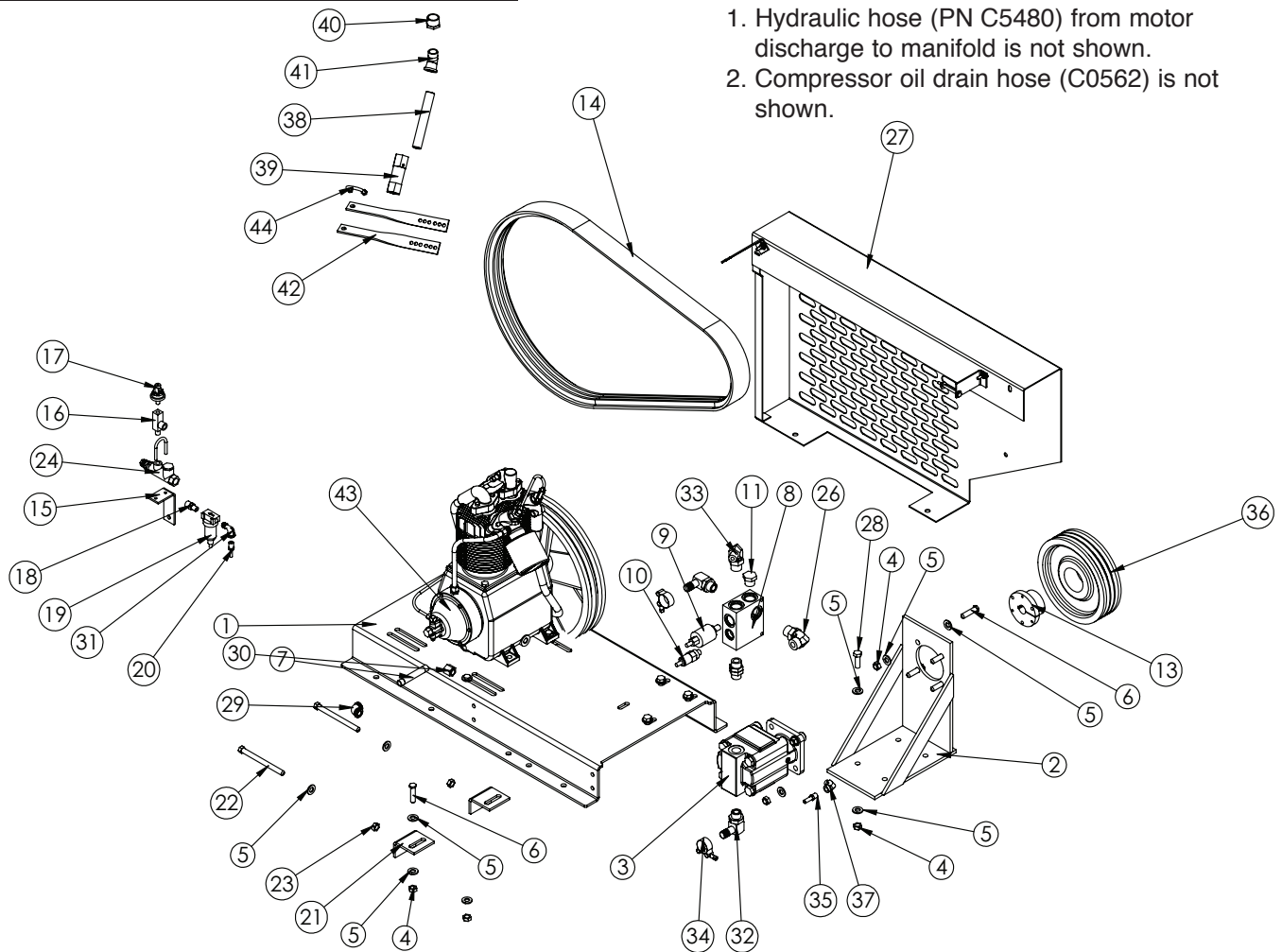

Notes:

1. Hydraulic hose (PN C5480) from motor discharge to manifold is not shown.
2. Compressor oil drain hose (C0562) is not shown.

ITEM	PART	DESCRIPTION	QTY.
1	10642PC	BASE WLDMT R40/R70 TOP MT	1
2	B0179PC	BRKT HYD MOTOR MOUNT CPRSR	1
3	10093	MOTOR HYD M330A842VREB10-43	1
4	C6106	NUT 0.50-13 HHGR5 NYLOC	12
5	D0790	WASHER 0.50 FLAT GR8	26
6	0501	CAP SCR 0.50-13X2.00 HHGR5	8
7	20456	NIPPLE 0.38X4.00 BRASS	1
8	C3075	BLOCK AL CPRSR SHD 66	1
9	C4913	VALVE SOLND	1
10	C4914	VALVE RELIEF CP-200-1-B-0-A-C	1
11	C6015	FTG 0.75 PLUG 12-P5ON	1
12	C5549	FTG ORB/JIC STRT CONNT 12-F5OX-S	1
13	C6188	BUSHING 1.00	1
14	9256	BELT 3B90 GATES (DAYCO RBP90-3)	1
15	4703	BRKT UNLOADER VALVE MNT SHD66DD	1
16	8277	FTG ST L 0.25 MNPT/0.125 FNPT SPL	1
17	C0864	SWITCH PRES HOBBS	1
18	20330	FTG 0.38-0.25 FF HEX NIPPLE	1
19	C5662	FILTER METAL BOWL 0.25	1
20	C2274	FTG HOSE BARB .25 HOSE X .25 MNPT	1
21	B0843PC	ANGLE TIGHTENER CPRSR WLDMT	2
22	8697	CAP SCR 0.50-13X6.00 ALL THREAD GR5	2

ITEM	PART	DESCRIPTION	QTY.
23	0537	NUT 0.50-13 HH	2
24	3853	VALVE PILOT 145/175 PSI RCL-S	1
25	C6064	U BOLT 0.25X1.25X2.25	1
26	C5968	FTG ADAPT 90 12-C5OLO-S	1
27	28007	COVER KIT SHD-245	1
28	0359	CAP SCR 0.50-13X1.50 HHGR5	4
29	20452	ELBOW 0.38 90 DEG BRASS	1
30	2772	CAP 8FNL-S	1
31	5418	ST EL 0.25 90 DEG BRASS 44-161	1
32	C0484	FTG #12 O'RING 0.75 BARB 90	2
33	C4227	FTG MF/MSTR 90 8-12 C5OLO-S	1
34	C6071	HOSE CLAMP 0.75	2
35	C2275	FTG HOSE BARB .38 HOSE X .25 MNPT	1
36	D1303	PULLEY SHEAVE 3 GROOVE 3B 94SK	1
37	C5908	FTG 0.25 ML ELL	1
38	20884	NIPPLE 0.75X4.00 BRASS	1
39	5480	VALVE CHECK 0.75 STANDARD	1
40	D1273	FTG 1.00-0.75 BUSH RED BRASS	1
41	D1869	FTG 0.75-45 DEG ELBOW BRASS	1
42	D0847	BRKT 1.1.00 TWIST 45 DEG SHD66DD	2
43	C1088	CPRSR CHMP R40A-HU	1
44	C4941	CLAMP MUFFLER 1 1/8	1

R40 Breakdown Assembly

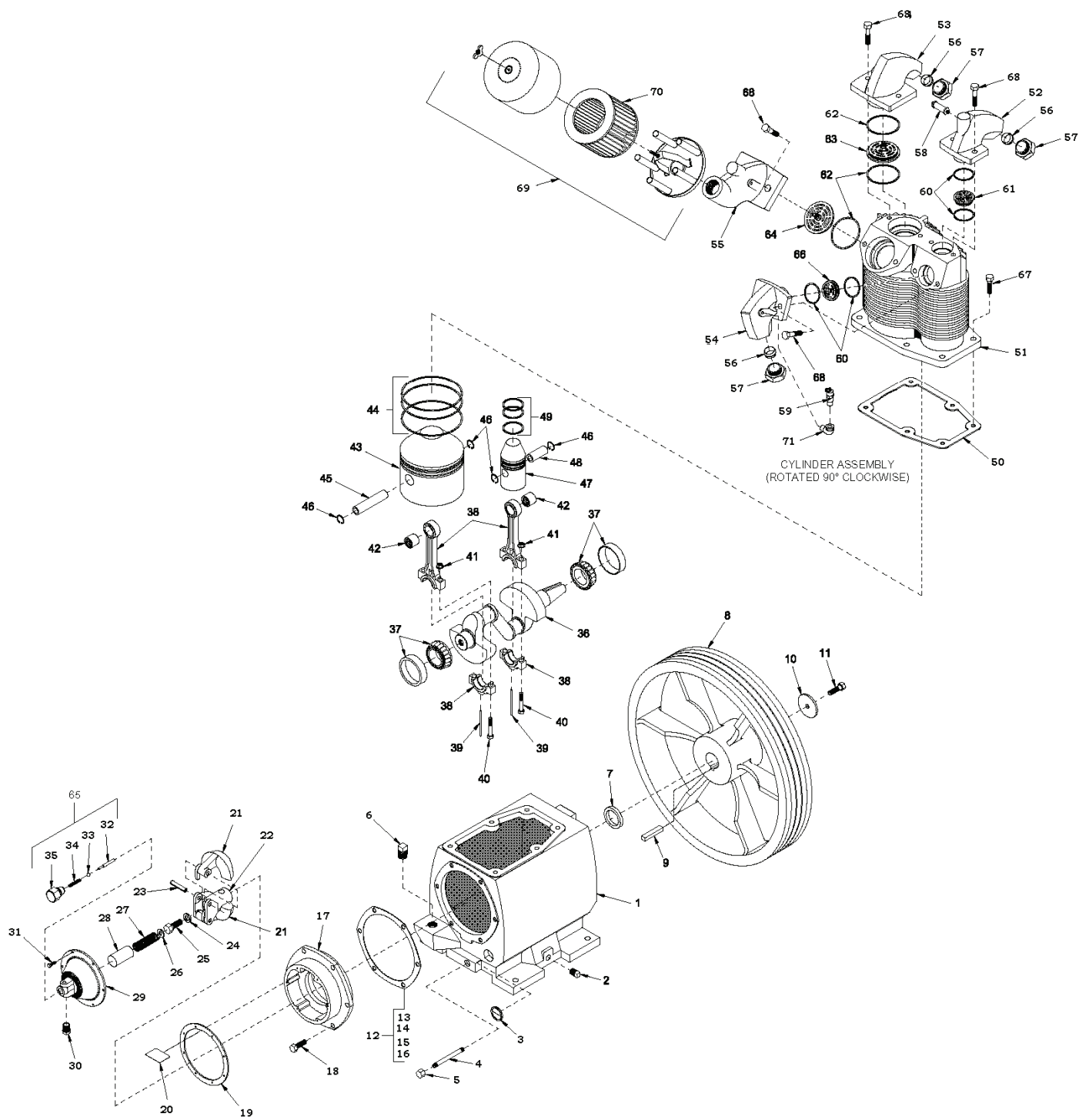

R40 Breakdown Parts List

Ref. No.	Description	Part Number	Qty.
1	Crankcase	M1453	1
2	Pipe plug	64AA5	1
3	Oil level gauge	RE 714	1
4	Pipe nipple	M492	1
5	Pipe cap	M461	1
6	Pipe plug	64A5	1
7	Oil seal	P03433A	1
8	Flywheel	P05723C	1
9	Key	M1506	1
10	Flywheel washer	M1394	1
11	Hex head cap screw	M2265	1
12	Governor housing gasket set (includes items 13, 14, 15 & 16)	Z775	1
13	Gasket, .031" thick	M1398	1
14	Gasket, .015" thick	M1399	1
15	Gasket, .010" thick	M1400	1
16	Gasket, .006" thick	M1401	1
17	Governor housing	P12274C	1
18	Hex head cap screw	M2345	6
19	Governor housing cover gasket	SE 1489	1
20	Baffle plate	P12381A	1
21	Governor weight	SE 582B	2
22	Governor weight spindle	SE 583B	1
23	Governor weight pin	SE 592A	2
24	Lock washer	M3468	1
25	Hex head cap screw	M2345	1
26	Flat washer	M912A	1
27	Main governor spring	SE 590	1
28	Governor spring sleeve	SE 587	1
29	Governor housing cover	RE 10100A	1
30	Unloader muffler assembly	Z4593	1
31	Hex head machine screw	M3473	6
32	Release valve plunger	SE 586B	1
33	Release valve ball	P07841A	1
34	Release valve spring	SE 591	1
35	Release valve cap	NR101	1
36	Crankshaft	M1458	1
37	Main bearing	Z6506	1
38	Connecting rod assembly (includes items 43, 44, 45 & 46)	Z658	2
39	Oil dipper	P03440A	2
40	Connecting rod bolt	P03458A	4
41	Connecting rod nut	P03459A	4
42	Piston pin bearing	P03430A	2
43	Low pressure piston with pin	ZM1906	1
44	Low pressure piston ring set	Z9087	1
45	Low pressure piston pin	M1395	1
46	Piston pin retaining ring	P03434A	4
47	High pressure piston with pin	ZM1393	1
48	High pressure piston pin	M1383	1
49	High pressure piston ring set	Z9088	1
50	Cylinder flange gasket	M1391	1

R40 Breakdown Parts List

Ref. No.	Description	Part Number	Qty.
51	Cylinder	P 05863D	1
* 52	High pressure intake manifold	M1431	11
53	Low pressure discharge manifold	M1423	1
54	High pressure discharge manifold (Non-Base Mount Units)	M1508	1
54	High pressure discharge manifold (Base Mount Units)	P05748A	1
* 55	Low pressure intake manifold	P 09711D	1
56	Ferule	P 06064A	3
57	Compression nut	M1418	3
58	Interstage pressure relief valve	M3685	1
59	Discharge pressure relief valve	P 09704A	1
60	High pressure valve gasket	P 07353A	4
61	High pressure intake valve assembly	Z784	1
62	Low pressure valve gasket	P 07352A	3
63	Low pressure discharge valve assembly	Z274	1
64	Low pressure intake valve assembly	Z273	1
65	Release valve kit (includes items 32, 33, 34, & 35)	Z12414A	1
66	High pressure discharge valve assembly	Z785	1
67	Hex head cap screw	M3461	6
68	Hex head cap screw	P 04779A	8
69	Intake filter	P 07447A	1
70	Intake filter element	P 05051A	1
71	90° Elbow	M3088	1
	Complete compressor pump gasket set (items 12, 19 & 50)	Z10888	1
	Low pressure piston kit (items 43, 44, 45 & 46)	Z9108	1
	High pressure piston kit (items 46, 47, 48 & 49)	Z9107	1
	Complete compressor pump ring set (items 44 & 49)	Z9109	1
	Valve set with gaskets (items 60, 61, 62, 63, 64, & 66)	Z656	1
	Valve gasket kit (items 60 & 62)	Z657	1

* Intake manifolds shown for Start-Stop units only. See page 26 for Head Unloader manifolds.

Replacement Parts

SHD138 Compressor - Replacement Parts

Hydraulic Components/Drive Parts	
C4914	Relief Valve
C4913	Solenoid Valve
10093	Hydraulic Motor
C6188	Bushing 1.00" Pulley
D1303	Sheave Pulley
9256	Belt 3B90 Gates
C3075	Aluminum Manifold Block
C6225	Hydraulic Oil Filter

Electrical/Air Pressure Components	
C0864	Pressure Switch (Hobbs)
3853	Pilot Valve 145/175 PSI
C5662	Filter Metal Bowl

Air Filter Components/Service Kits	
26803	Filter Assembly R40
4562	Filter Element (only)
62133	SHD138 Service Kit

Champion Compressor Components	
C1088	Compressor R40

Centrifugal Unloader Components	
C0896	Release Valve Assembly Kit
7417	Muffler Assembly Unloader

Manifold/Valve Components	
13731	Valve Assembly (Low Pressure Intake)
13732	Valve Assembly (Low Pressure Exhaust)
13733	Valve Assembly (High Pressure Intake)
13734	Valve Assembly (High Pressure Exhaust)
4563	Complete Valve Gasket Set
4564	Complete Valve Set W/Gaskets
C1183	Pressure Relief Valve

Troubleshooting

If symptoms of poor performance develop, the following chart can be used as a guide to investigate and correct the problem. When diagnosing faults in operations of the air compressor, always check that the hydraulic power source is supplying the correct hydraulic flow and pressure that is listed in the compressor specification section of this manual.

Problem	Possible Cause	Solution
Compressor will not start:	PTO not engaged.	Engage PTO.
	Emergency brake off.	Fully engage parking brake.
	Blown fuse.	Replace fuse.
	Loose or broken power/ground wire.	Repair connection.
	Compressor manifold solenoid will not engage.	Repair wiring to coil. Replace valve.
Compressor runs slow or slows down during operation:	Loose air lines or hoses.	Tighten air lines and hose connections.
	Hydraulic flow too low.	Check and reset flow.
	Hydraulic motor worn.	Replace with new motor.
	Hydraulic relief set too low.	Readjust relief valve.
	Faulty compressor valves.	Clean or replace.
	Pilot valve leaking air.	Replace pilot valve.
	Centrifugal unloader valve leaking.	Remove the governor release valve cap, giving access to the unloader pressure release valve spring and ball - Clean thoroughly and reassembly.
	Hydraulic oil temp high.	Hydraulic fluid low. Hydraulic reservoir size incorrect.
Compressor will lock up after operating for a short period:	Hydraulic motor drive coupler loose.	Reposition and tighten coupler.
	Faulty hydraulic relief valve.	Remove relief valve, inspect o-rings and backup seals or replace relief valve.
	Faulty check valve.	Clean or replace check valve.
Compressor runs hot:	Dirty after cooler or intercooler tubing.	Remove and clean.
	Faulty compressor valves.	Clean or replace valves.
	Dirty intake muffler.	Clean or replace.
	Low crankcase oil level.	Add compressor oil as needed.

Problem	Possible Cause	Solution
Compressor will not shut down:	Air line or air hose leaks.	Tighten air lines or hose connections.
	Misadjustment of pilot valve.	Adjust valve per manual specifications.
	Pilot valve leaking air	Clean or replace pilot valve.
	Centrifugal unloader valve is leaking.	See "Compressor runs slowly" section.
	Moisture or rust contamination.	Remove filter bowl. Fill with WD40 lubricant. Open air tank valve. Run compressor for 10 minutes. Partially close air tank valve and cycle compressor. Repeat as needed.
Compressor continues to build air during idle mode:	Faulty low pressure intake valve.	Clean or replace low pressure intake valves.
	Leaking or misadjustment of the pilot valve.	Tighten or adjust valve per manual specs.
Compressor will not speed up when compressor is activated:	Air reservoir full.	Drain air from reservoir.
	Faulty pressure switch.	Test for 12 volt power on both the "C" and "NC" side of the terminals. If no power on "NC" side of pressure switch, replace switch.
	No 12 volt power to coil solenoid valve located on hydraulic manifold.	Check fuse. Check ground wires. Check chassis emergency brake switch.
Engine RPM will not increase when compressor is activated:	Loose wiring.	Check wiring to : Solenoid valve, pressure switch, ground wiring.
	Faulty pressure switch.	Replace pressure switch.
	Faulty speed control.	Check speed control wiring for loose or broken connections. Check relay (For ECM operated speed settings.)
Compressor cycles or runs often:	Faulty pressure switch.	Replace pressure switch.
	Excessive water in air reservoir.	Drain air reservoir.
	Pip lines leaking air.	Tighten or replace lines.
	Misadjustment of pilot valve.	Adjust valve per manual specifications.
	Air leaking from pilot valve.	Clean, adjust, or replace.
	Check valve leaking.	Clean or replace.
Chassis engine RPM continue to operate at high speed when air receiver reaches maximum capacity:	Faulty pressure switch.	Replace pressure switch.
	Pressure switch wiring.	Wires place on pressure switch incorrectly or loose ground wire.



Limited Warranty Statement

American Eagle warrants products designed and manufactured by Stellar to be free from defects in material and workmanship under proper use and maintenance. Products must be installed and operated in accordance with Stellar's written instructions and capacities. The warranty period shall cover the following:

Twelve (12) month warranty on parts and
Twelve (12) month repair labor

The warranty period shall begin from the date recorded by American Eagle as the in-service date. This date will be derived from the completed warranty registration card. In the event a warranty registration card is not received by American Eagle, the factory ship date will be used. New compressors will be issued on all returns within 90 days of this factory ship date. After 90 days, American Eagle reserves the right to issue remanufactured compressors. Regardless of in-service date, warranty coverage does not extend beyond twenty-four (24) months from date of manufacture.

American Eagle's obligation under this warranty is limited to, and the sole remedy for any such defect shall be, the repair and/or replacement (at American Eagle's option) of the unaltered part and/or component in question. American Eagle after-sales service personnel must be notified by telephone, fax, or letter of any warranty-applicable damage within fourteen (14) days of its occurrence. If at all possible, American Eagle will ship the replacement part within 24-hours of notification by the most economical, yet expedient, means possible. Expedited freight delivery will be at the expense of the owner.

Warranty claims must be submitted and shall be processed in accordance with American Eagle's established warranty claim procedure. American Eagle after-sales service personnel must be contacted prior to any warranty claim. A return materials authorization (RMA) account number must be issued to the claiming party prior to the return of any warranty parts. Parts returned without prior authorization will not be recognized for warranty consideration. All damaged parts must be returned to American Eagle freight prepaid; freight collect returns will be refused. Freight reimbursement of returned parts will be considered as part of the warranty claim.

Warranty service will be performed by any American Eagle new equipment distributor, or by any American Eagle-recognized service center authorized to service the type of product involved, or by the American Eagle factory in the event of a direct sale. At the time of requesting warranty service, the owner must present evidence of date of delivery of the product. The owner shall be obligated to pay for any overtime labor requested of the servicing company by the owner, any field service call charges, and any towing and/or transportation charges associated with moving the equipment to the designated repair/service provider.

All obligations of American Eagle and its authorized dealers and service providers shall be voided if someone other than an authorized American Eagle dealer provides other than routine maintenance service without prior written approval from American Eagle. In the case repair work is performed on a American Eagle-manufactured product, original American Eagle parts must be used to keep the warranty in force. The warranty may also be voided if the product is modified or altered in any way not approved, in writing, by American Eagle.

The owner/operator is responsible for furnishing proof of the date of original purchase of the American Eagle product in question. Warranty registration is the ultimate responsibility of the owner and may be accomplished by the completion and return of the American Eagle product registration card provided with the product. If the owner is not sure of registration, he is encouraged to contact American Eagle at the address below to confirm registration of the product in question. This warranty covers only defective material and workmanship. It does not cover depreciation or damage caused by normal wear and tear, accident, mishap, untrained operators, or improper or unintended use. The owner has the obligation of performing routine care and maintenance duties as stated in American Eagle's written instructions, recommendations, and specifications. Any damage resulting from owner/operator failure to perform such duties shall void the coverage of this warranty. The owner will pay the cost of labor and supplies associated with routine maintenance.

The only remedies the owner has in connection with the breach or performance of any warranty on the American Eagle product specified are those set above. In no event will American Eagle, the American Eagle distributor/dealer, or any company affiliated with American Eagle be liable for business interruptions, costs of delay, or for any special, indirect, incidental, or consequential costs or damages. Such costs may include, but are not limited to, loss of time, loss of revenue, loss of use, wages, salaries, commissions, lodging, meals, towing, hydraulic fluid, or any other incidental cost.

All products purchased by American Eagle from outside vendors shall be covered by the warranty offered by that respective manufacturer only. American Eagle does not participate in, or obligate itself to, any such warranty.

American Eagle reserves the right to make changes in design or improvement upon its products without imposing upon itself the same upon its products theretofore manufactured.

This warranty will apply to all American Eagle Drawer Sets and Compressed Air Systems shipped from American Eagle's factory after July 1, 2005. The warranty is for the use of the original owner only and is not transferable without prior written permission from American Eagle.

THIS WARRANTY IS EXPRESSLY IN LIEU OF ANY OTHER WARRANTIES, EXPRESS OR IMPLIED, INCLUDING ANY WARRANTY OF MERCHANTABILITY OR FITNESS FOR A PARTICULAR PURPOSE. REMEDIES UNDER THIS WARRANTY ARE LIMITED TO THE PROVISION OF MATERIAL AND SERVICES, AS SPECIFIED HEREIN. AMERICAN EAGLE INDUSTRIES, INC. IS NOT RESPONSIBLE FOR INCIDENTAL OR CONSEQUENTIAL DAMAGES.

Revision Date: March 2006

Document Number: 37042