

Owner's Manual

Safety, Installation, Maintenance, and Operation

Model V230 Air Compressor

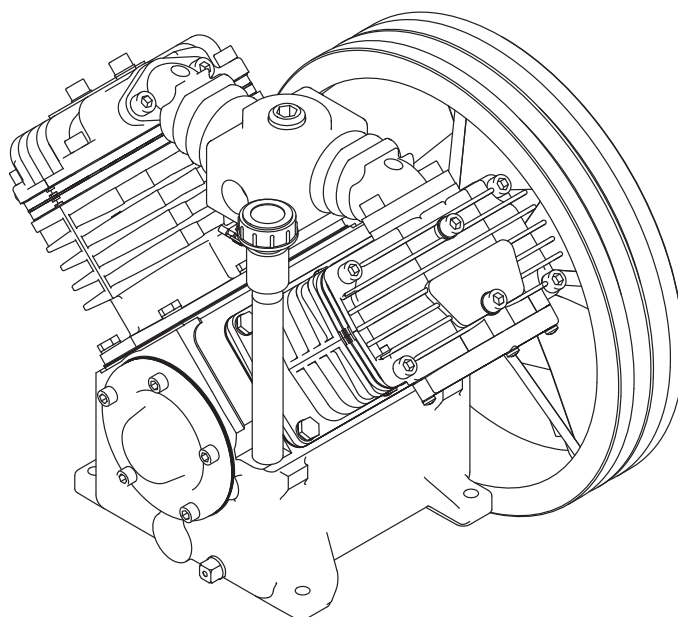

American Eagle, Inc.
740 N. State Street
PO Box 169
Garner, IA 50438
800-392-3015
Fax: 641-923-9099
www.americaneagleacc.com

Introduction

American Eagle Compressors are designed to provide safe and dependable service for a variety of operations. With proper use and maintenance, American Eagle Compressors will operate at peak performance for many years.

This manual contains information vital to the safe use and efficient operation of this unit. Following the information provided within this manual can ensure the longevity of the compressor. Carefully read and study the operator's manual before using the unit. Failure to adhere to the instructions could result in property damage or even serious bodily injury to the operator or others close to the compressor.

A copy of this manual is provided with every compressor and shall remain with the compressor at all times. Information contained within this manual does not cover all maintenance, operating, or repair instructions pertinent to all possible situations. This manual is not binding. American Eagle reserves the right to change, at any time, any or all of the items, components, and parts deemed

necessary for product improvement or commercial/production purposes. This right is kept with no requirement or obligation for immediate mandatory updating of this manual.

This product manual is not intended as a training manual for beginners or unskilled operators. This manual offers guidelines for correct and safe usage of the compressor, maintenance, and troubleshooting. If more information is required or technical assistance is needed, please contact AE Technical Support.

Some sections of this manual contain information pertaining to all American Eagle manufactured compressors and may or may not apply to your specific model.

If this manual becomes damaged, misplaced, or unreadable at any point, or if you feel that any part of this manual is unclear or incorrect, please contact AE Technical Support at 800-321-3741 or email at service@americaneagleacc.com

**For Technical Questions, Information, Parts, or Warranty, Call Toll-Free at
800-321-3741**

Hours: Monday - Friday, 8:00 a.m. - 5:00 p.m. CST

Or email at the following addresses:

Technical Questions, and Information

service@americaneagleacc.com

Order Parts

parts@americaneagleacc.com

Warranty Information

warranty@americaneagleacc.com

Table of Contents

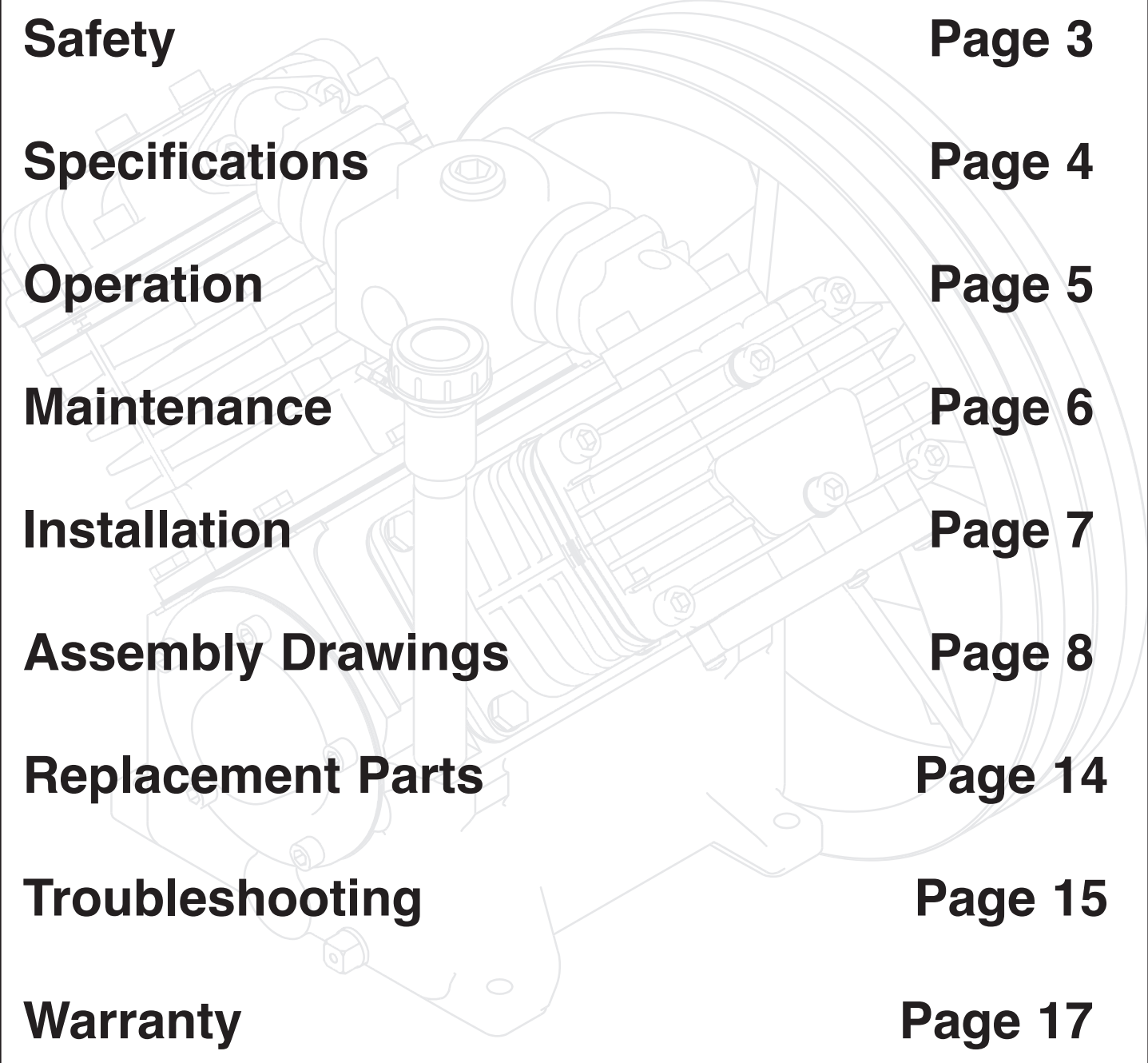

Safety	Page 3
Specifications	Page 4
Operation	Page 5
Maintenance	Page 6
Installation	Page 7
Assembly Drawings	Page 8
Replacement Parts	Page 14
Troubleshooting	Page 15
Warranty	Page 17

Safety

This manual contains vital information for the safe use and efficient operation of this unit. Carefully read the operators manual before starting the unit. Failure to adhere to the instructions could result in serious bodily injury or property damage.

The V230 Air Compressor will provide safe and dependable service if operated according to instructions. Read and understand the safety precautions given in this manual and on the decals attached to the shields. Failure to do so can result in personal injury or equipment damage.

Operators and maintenance personnel must always comply with the safety precautions. These precautions are given here for your safety. Review them carefully before operating the compressor and before performing maintenance or repairs.

Supervising personnel should develop additional precautions relating to the specific work area and local safety regulations.

Precautions

Always wear safety equipment such as goggles, ear plugs and head protection at all times when operating the compressor.

Do not inspect or clean the compressor while the power source is connected. Accidental engagement of the tool can cause serious injury.

Before performing any maintenance on the compressor, place a warning tag on the power source or disconnect the belt from the compressor clutch to prevent accidental startup of the compressor.

Establish a training program for all operators to ensure safe operation.

Do not operate the compressor unless thoroughly trained or under the supervision of an instructor.

Do not operate the compressor if it is damaged, improperly adjusted or not completely or properly assembled.

Never operate the compressor with any of the guards removed. Do not attempt to adjust or disable the compressors air pressure relief valve. This valve limits the air pressure to 150 PSI.

The surface of the air compressor may reach temperatures above 150 degrees. Touching these surfaces during operation can cause burns.

The air taken in by the air compressor must be free of flammable fumes and vapors.

The compressor must be installed in a level position to provide proper lubrication. Most air compressor failure is caused by improper lubrication.

Use and operate this air compressor only in full compliance with all pertinent O.S.H.A. requirements and all Federal, State and Local codes or requirements

Specifications

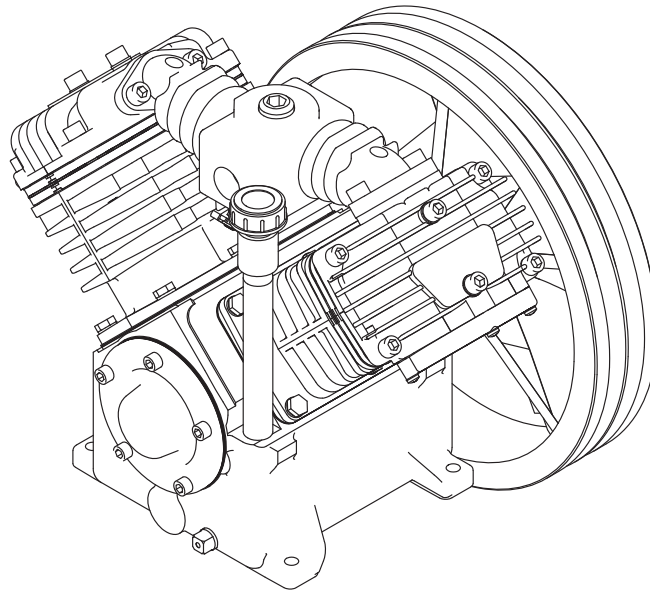

Compressor System Description

- | | |
|---|---|
| <ul style="list-style-type: none"> • Cast Iron Crankcase Casting • Cast Aluminum Cylinder Heads • High Temperature Precision Pistons • Stainless Steel Reed Valves • Heavy Duty Journal Bushings • Pulsation Manifold | <ul style="list-style-type: none"> • Heavy Ductile Iron Crankshaft • Micro-honed Connecting Rods • Tapered Roller Bearings • Pressure Lubricated System • Oil Pressure Gauge |
|---|---|

General Information

- Model:
- Weight:
- Displacement @ 1200 RPM:
- Delivery:
- Maximum Working Pressure:
- Oil Capacity:
- Cylinders:
- Pressure switch presets:

V230
80 lbs.
36 CFM
23 CFM @ 100 PSI
155 PSI
1 Quart
Four Cylinder(Single Stage)
Engage - 115 PSI
Disengage - 150 PSI

Operation

Each compressor is bench tested under load at the factory to ensure proper break-in and operation. While it is not necessary to follow any break-in procedure, the following checks should be made before putting the unit into service and periodically during use.

Before Start-Up

Check the oil level in the compressor with the dipstick on the unit. If oil is needed, use American Eagle synthetic compressor oil (P/N C0087) or an equivalent synthetic oil. **Note: There may be oil left in the crankcase from the factory bench test. Overfilling may cause the compressor to back blow oil. Always check the oil level and fill to the designated marking on the dipstick before putting the unit into service.**

Check the air intake filters on each head to make certain that they are clean and unobstructed. Dirty air filters are a possible cause of reduced air output.

GENERAL INFORMATION

To use the compressor, start the engine and engage the system with the compressor toggle switch. Through the pressure switch the system will now function automatically. Once engaged, adjust the engine speed control to ensure that the compressor speed does not exceed 1300 RPM under load.

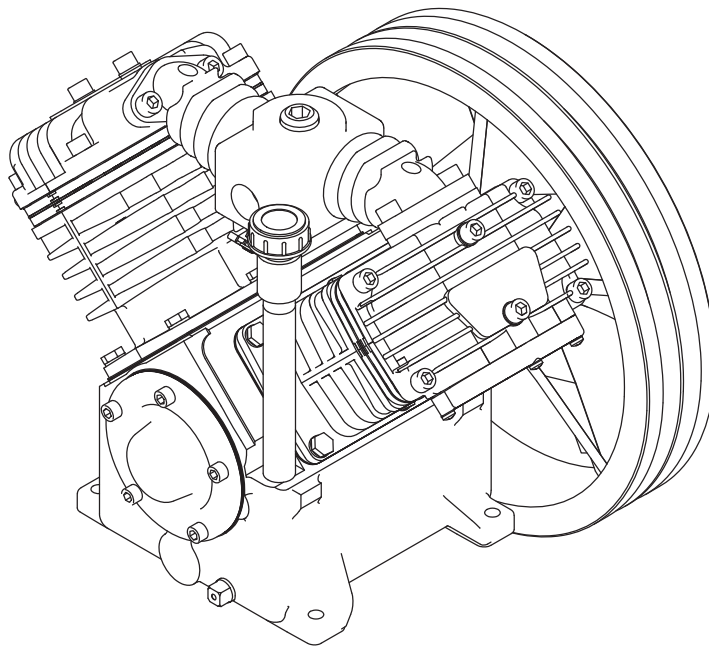

If questions arise during operation, please call our customer service department at (800) 321-3741

Maintenance

The following table is a list of routine maintenance items, including service intervals. Service intervals are listed as hours, days, or weeks, whichever occurs first. American Eagle recommends that these service intervals be followed.

Service Intervals				
Maintenance operation	Daily	Weekly	Monthly	Hourly
Drain air tanks	✓	✓	✓	✓
Check crankcase oil level	✓			
Check fittings and airlines	✓			
Inspect clutch and belt	✓			
Inspect and clean air intake filters		✓		
Clean and operate safety valves		✓		
Inspect check valve		✓		
Inspect and clean compressor valves			6	
Replace air filters			3	
Tighten all fittings and fasteners			3	
Check all electrical connections			3	
Check compressor reed valves				250
Inspect and clean air check valve				250
CHANGE CRANKCASE OIL (see footnote below)				

Under normal operating conditions, oil changes are required every 3 months. When operating in a dirty environment, change the oil more frequently as your particular operating condition dictates.

**USE AE SYNTHETIC COMPRESSOR OIL P/N C0087.
COMPRESSOR CRANKCASE CAPACITY IS TWO QUARTS.**

Installation

COMPONENT INSTALLATION

This section pertains to the installation of the air compressor, and other related items. The instructions are intended as a guide to assist you with particular installation. These instructions will provide only general information.

COMPRESSOR INSTALLATION:

Install compressor-mounting kit per manufacturer instructions. Set the compressor into place and inspect for proper alignment. Readjust if necessary. Using four (4) cap screws, flat washers, and nyloc nuts, secure the compressor in place. The compressor is air cooled, and must have a clean supply of air. Adequate space must be provided for proper circulation of air.

Torque and Procedure Chart

Pulsation Chamber Assembly

Torque Value: 31 FT. LBS.

Procedure: See Head Installation Procedure Section

Head Assembly

Torque Value: 31 FT. LBS.

Assemble both heads on the cylinders with head bolts started only, not tight. Set pulsation chamber in place between heads, making sure the "O" ring is in place in each head. Screw the (4) chamber mounting bolts down but not tight. Snug (6) head bolts in each head to light torque. Tighten (4) chamber bolts to 31 Ft-lbs. torque. Tighten (6) head bolts in each head to 31 Ft-lbs. torque, doing the (2) long center bolts first and the (4) short bolts last. After five hours of use re-torque bolts to 31 Ft-lbs.

Cylinder Assembly

Torque Value: 20 FT. LBS.

Procedure: After assembling cylinder over pistons and setting into place, tighten (6) cap screws finger tight. In a criss-cross pattern, tighten bolts evenly so all bolts are hand snug. Again in a criss-cross pattern torque each bolt to 20 Ft-lbs., checking each bolt twice. After five hours of use, re-torque bolts to 20 Ft-lbs.

Connecting Rod Assembly

Torque Value: 18 FT. LBS.

Procedure: Assemble rod onto the crankshaft taking care to align the machined surfaces together and tighten cap screws finger tight. Tighten bolts until hand tight and torque to 18 Ft-lbs. Check twice the torque reading before final assembly of the cylinders.

Assembly Drawings

Crankcase Group

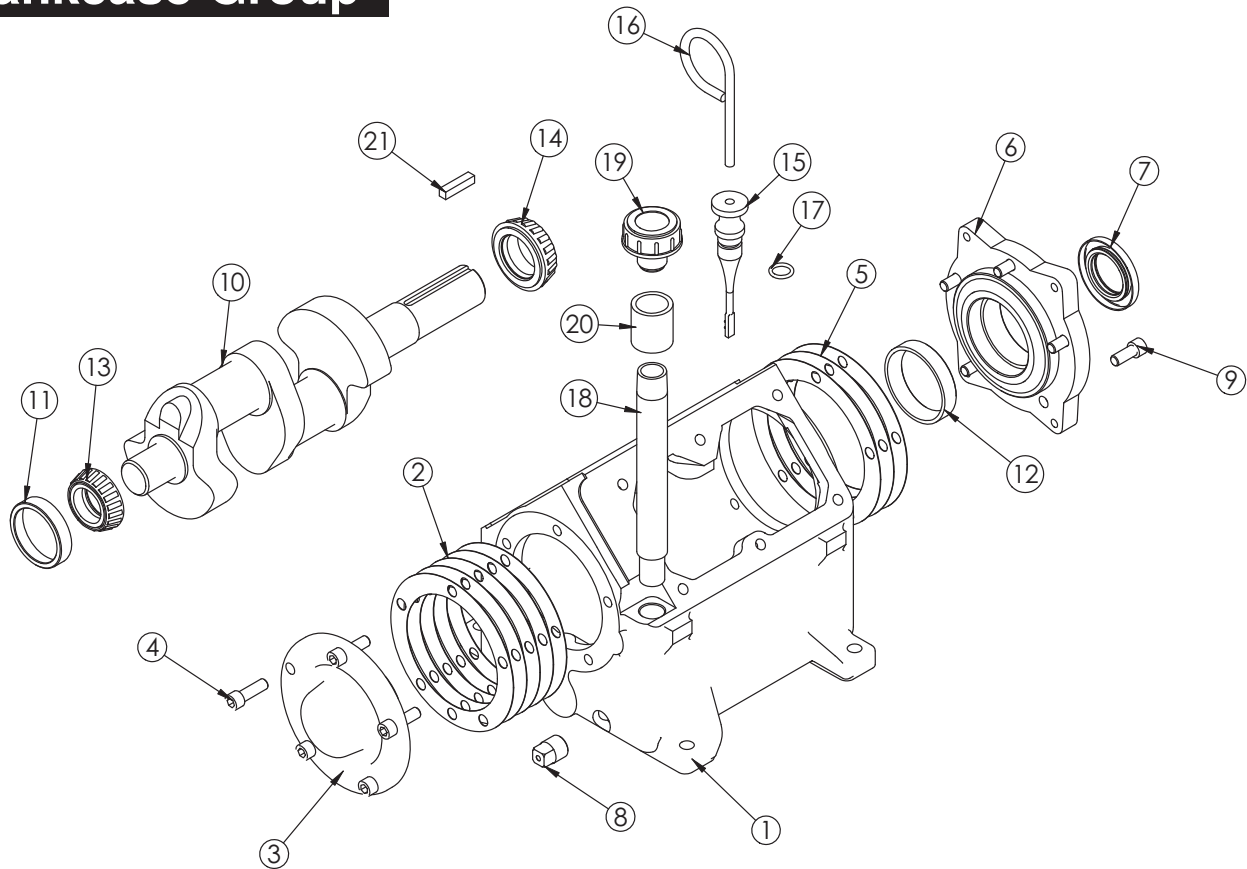

CRANK CASE GROUP

ITEM	PART	DESCRIPTION	QTY.
1	22861	CRANK CASE V230	1
2	5822	GASKET BEARING CARRIER-V480 (.015)	5
3	22837	BEARING CARRIER V230	1
4	6034	SCREW 0.31-18X1.00 SHC	5
5	C6271	FRONT PL GASKET	3
6	5826	BEARING CARRIER CLUTCH PLT V480	1
7	5825	BEARING SEAL V480	1
8	5815	OIL DRAIN PLUG	1
9	5813	CAP SCR 0.31-18X0.75 SH	5
10	22831	CRANKSHAFT V230 S	1
11	C1164	BEARING CUP (L44610)	1
12	C1163	BEARING CUP (LM67010)	1
13	C0855	BEARING CONE	1
14	C0856	BEARING CONE LM67048	1
15	22839	DIPSTICK (V230/V360)	1
16	22686	HANDLE DIPSTICK OIL CHECK V480	1
17	C0041	O'RING-112	1
18	C0062	BREATHER BODY	1
19	22868	BREATHER CPRSR .50NPT NY8	1
20	C5929	COUPLER 0.50 BLK	1
21	23047	KEY FLYWHEEL 1/4	1

Head Group

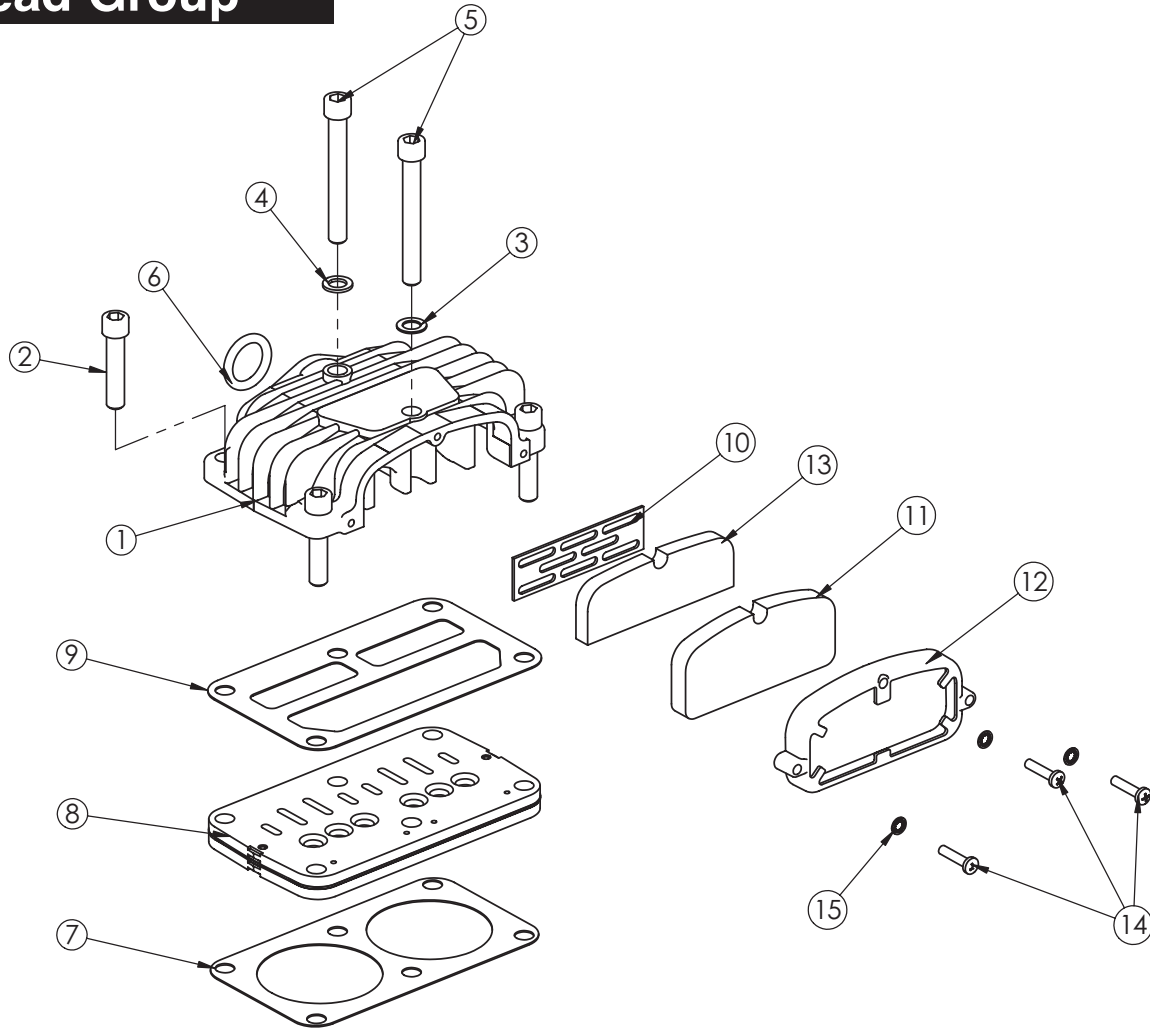

HEAD GROUP

ITEM	PART	DESCRIPTION	QTY.
1	6030	HEAD A/C V230 O/S	1
2	C1586	CAP SCR 0.38-16X1.75 SH HEAD BOLT	4
3	5828	WASHER LONG HD BOLT (BRASS)	1
4	C0040	WASHER HD BOLT STL	1
5	C1582	CAP SCR 0.38-16X3.00 SH HEAD BOLT	2
6	C0291	O'RING-214 VITON 9009-75	1
7	C0043	GASKET VALVE PLATE 143/230/360	1
8	24103	VALVE PLATE SUB ASM O/S	1
9	C0310	GASKET HEAD 143/230/360/480	1
10	C0297	FILTER SCREEN	1
11	C0296	FILTER FOAM	1
12	C0294	FILTER RETAINER	1
13	C0715	FILTER FOAM	1
14	C0300	SCREW #10-32X0.88 NF	3
15	23875	WASHER #10 STAR CPRSR	3

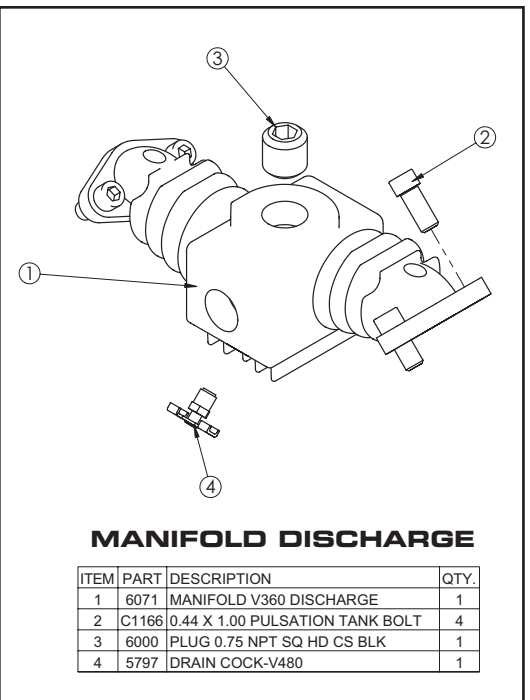

MANIFOLD DISCHARGE

ITEM	PART	DESCRIPTION	QTY.
1	6071	MANIFOLD V360 DISCHARGE	1
2	C1166	0.44 X 1.00 PULSATION TANK BOLT	4
3	6000	PLUG 0.75 NPT SQ HD CS BLK	1
4	5797	DRAIN COCK-V480	1

Head Options

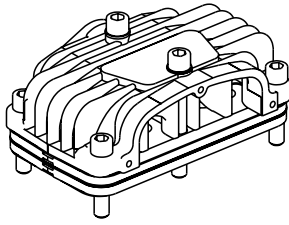

#5808
Aluminum Air Cooled
Imbedded Filter & 3/4"
Threaded NPT Discharge

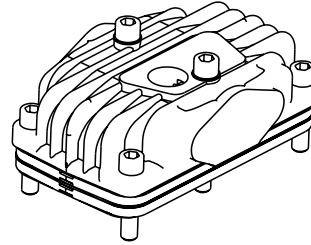

#15195
Cast Iron Air Cooled
3/4" Threaded Intake Port
on Top of Head with
3/4" Discharge Port

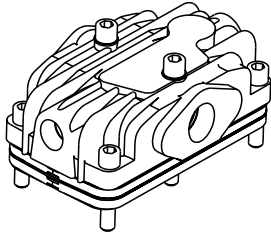

#C1632
Aluminum Water Cooled
3/4" Threaded Inlet & 3/4"
Threaded NPT Discharge

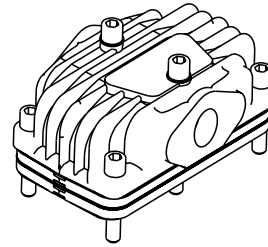

#3897
Cast Iron Air Cooled
3/4" Threaded Inlet & 3/4"
Threaded NPT Discharge

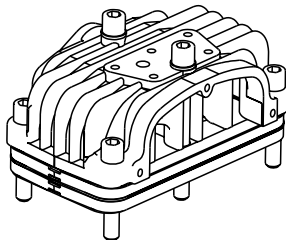

#22996
Cast Iron Air Cooled
Imbedded Filter & 3/4"
Threaded NPT Discharge
with Head Unloader Ports

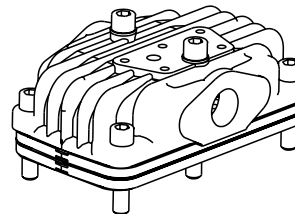

#23039
Cast Iron Air Cooled
3/4" Threaded Inlet & 3/4"
Threaded NPT Discharge
with Head Unloader Ports

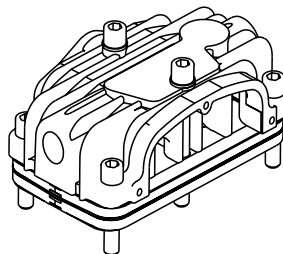

#C1631
Aluminum Water Cooled
Imbedded Filter & 3/4"
Threaded NPT Discharge

Flywheel Options

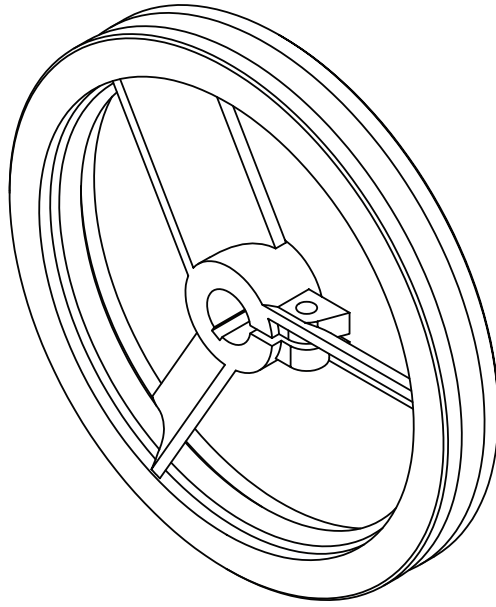

22997
12" - B GROOVE

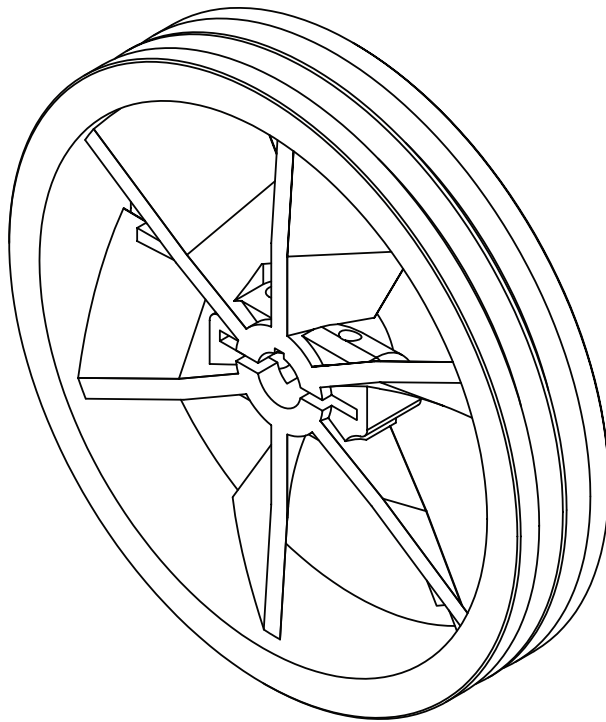

22838
14" - DUAL GROOVE

Optional Head Unloader

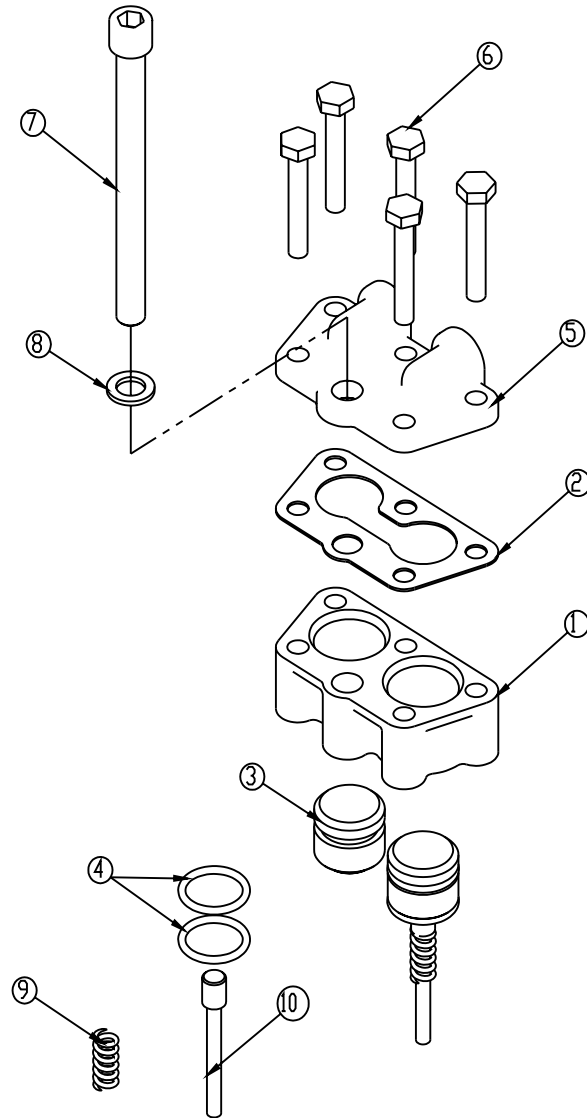

PN 23200

ITEM	PART	DESCRIPTION	QTY.	ITEM	PART	DESCRIPTION	QTY.
1	22591	BODY HEAD UNLOADER CPRSR	1	6	0220	CAP SCR 0.25-20 X 1.50 HHGR5	5
2	22599	GASKET UNLOADER	1	7	22596	CAP SCR 0.38-16X4.00 SH HEAD BOLT	1
3	22593	PISTON HEAD UNLOADER CPRSR	2	8	C0040	WASHER HD BOLT STL	1
4	22598	O'RING 2-116 HEAD UNLOADER CPRSR	4	9	22597	SPRING PLUNGER PIN UNLOADER CPRSR	2
5	22592	COVER HEAD UNLOADER CPRSR	1	10	22594	PIN PLUNGER HEAD UNLOADER CPRSR	2

Replacement Parts

Overhaul Kit - P/N: 23346

Consisting of: Gasket Set (1)
Ring Set (1)
O-Ring (2)
Valve Plate (2)
Bearing Oil Seal (1)
Oil - 1 Qt
Inner Filter (2)
Outer Filter (2)

Gasket Set Complete - P/N: 23668

Ring Set Complete - P/N: C0069

Valve Plate Assembly - P/N: C0314

Consisting of: Valve Plate (1)
Top Head Gasket (1)
Bottom Head Gasket (1)

Crankshaft With Bearings: Straight Shaft - P/N: 23689

Canister Filter - P/N: 22867

Call 800-321-3741 to Order

Troubleshooting

If symptoms of poor performance develop, the following chart can be used as a guide to investigate and correct the problem. When diagnosing faults in operations of the air compressor, always check that the hydraulic power source is supplying the correct hydraulic flow and pressure that is listed in the compressor specification section of this manual.

Problem	Possible Cause	Solution
Compressor runs hot	Check compressor rotation Compressor reed valves Dirty intake filter Low oil Level Check valve leaking	Check fittings on hydraulic motor Inspect, clean or replace valves Clean filter assembly Level Add oil if needed Disassemble, clean, and re-install
Compressor does not run	Air reservoir full Hydraulic lines not connected Couplers or hoses blocked Air load against compressor Hydraulic pump not working Hydraulic motor not working Check valve leaking	Drain and activate pressure switch Connect lines Locate and remove restriction Relieve air pressure Check flow and pressure settings Inspect and repair Disassemble, clean, and reinstall
Compressor runs too slow	Compressor reed valves Check for hose leaks Hydraulic flow too low Hydraulic motor worn Power unit relief set too low Hydraulic system too hot Speed control not working	Inspect, clean or replace valves Tighten any hose fitting leaking Check and reset flow Replace with new motor Readjust relief valve Reservoir too small. Add cooler to system. Check power supply and readjust
Compressor will not stop	Air pressure switch set wrong Leaking hoses or fittings	Check points and setting on switch Tighten all fittings and hoses
Air output too low (air pressure okay)	Low compressor speed Air filter dirty Airlines leaking Check valve plugged	Refer to compressor too slow Inspect and clean Retighten hoses Remove and clean check valve
Compressor cycles (air not being used)	Leaks in air line Air pressure switch set wrong Dirt in solenoid valve	Tighten hoses and fittings Check cut-in and cutout settings Remove and clean

Problem	Possible Cause	Solution
Air Output low (Air Pressure Low)	Dirty air filter Intake reed valves malfunction Insufficient torque on head bolts	Inspect and clean filter If air back-flows from air filter, reed valve is faulty and needs to be replaced. Tighten bolts to required torque
Air pressure too low	Air pressure switch set wrong Air line leak Air consumption exceeds Compressor capacity Intake or exhaust valves damaged	Readjust high pressure setting Inspect and tighten loose hoses Check air demand for items using the air supply Inspect and replace
Air pressure too high	Pressure switch not operating Internal contamination Pressure switch not adjusted	Inspect and clean Inspect and clean Readjust to lower pressure
High crankcase oil usage	Oil level too high Oil leaks Piston rings worn or broken	Check oil level and drain if needed Inspect and repair gaskets or seals Replace rings
Blowing oil from crankcase breather	Blown head gasket Piston rings worn or broken Oil level in crankcase too high Hole in piston	Replace gasket Replace rings Check oil level and drain Replace piston
No lubricating oil pressure	Air lock in oil pump No oil in crankcase Pump suction blocked	Loosen oil gauge while compressor is running. When oil begins to flow from fitting, tighten oil gauge. Check oil level and add Remove oil intake plug and inspect intake and screen. Clean blockage.



Limited Warranty Statement

American Eagle warrants products designed and manufactured by Stellar to be free from defects in material and workmanship under proper use and maintenance. Products must be installed and operated in accordance with Stellar's written instructions and capacities. The warranty period shall cover the following:

Compressors:

Twelve (12) month warranty on parts and
Twelve (12) month repair labor

Drawer Sets:

Lifetime warranty on slides and hardware

The warranty period shall begin from the date recorded by American Eagle as the in-service date. This date will be derived from the completed warranty registration card. In the event a warranty registration card is not received by American Eagle, the factory ship date will be used. New compressors will be issued on all returns within 90 days of this factory ship date. After 90 days, American Eagle reserves the right to issue remanufactured compressors. Regardless of in-service date, warranty coverage does not extend beyond twenty-four (24) months from date of manufacture.

American Eagle's obligation under this warranty is limited to, and the sole remedy for any such defect shall be, the repair and/or replacement (at American Eagle's option) of the unaltered part and/or component in question. American Eagle after-sales service personnel must be notified by telephone, fax, or letter of any warranty-applicable damage within fourteen (14) days of its occurrence. If at all possible, American Eagle will ship the replacement part within 24-hours of notification by the most economical, yet expedient, means possible. Expedited freight delivery will be at the expense of the owner.

Warranty claims must be submitted and shall be processed in accordance with American Eagle's established warranty claim procedure. American Eagle after-sales service personnel must be contacted prior to any warranty claim. A return materials authorization (RMA) account number must be issued to the claiming party prior to the return of any warranty parts. Parts returned without prior authorization will not be recognized for warranty consideration. All damaged parts must be returned to American Eagle freight prepaid; freight collect returns will be refused. Freight reimbursement of returned parts will be considered as part of the warranty claim.

Warranty service will be performed by any American Eagle new equipment distributor, or by any American Eagle-recognized service center authorized to service the type of product involved, or by the American Eagle factory in the event of a direct sale. At the time of requesting warranty service, the owner must present evidence of date of delivery of the product. The owner shall be obligated to pay for any overtime labor requested of the servicing company by the owner, any field service call charges, and any towing and/or transportation charges associated with moving the equipment to the designated repair/service provider.

All obligations of American Eagle and its authorized dealers and service providers shall be voided if someone other than an authorized American Eagle dealer provides other than routine maintenance service without prior written approval from American Eagle. In the case repair work is performed on a American Eagle-manufactured product, original American Eagle parts must be used to keep the warranty in force. The warranty may also be voided if the product is modified or altered in any way not approved, in writing, by American Eagle.

The owner/operator is responsible for furnishing proof of the date of original purchase of the American Eagle product in question. Warranty registration is the ultimate responsibility of the owner and may be accomplished by the completion and return of the American Eagle product registration card provided with the product. If the owner is not sure of registration, he is encouraged to contact American Eagle at the address below to confirm registration of the product in question. This warranty covers only defective material and workmanship. It does not cover depreciation or damage caused by normal wear and tear, accident, mishap, untrained operators, or improper or unintended use. The owner has the obligation of performing routine care and maintenance duties as stated in American Eagle's written instructions, recommendations, and specifications. Any damage resulting from owner/operator failure to perform such duties shall void the coverage of this warranty. The owner will pay the cost of labor and supplies associated with routine maintenance.

The only remedies the owner has in connection with the breach or performance of any warranty on the American Eagle product specified are those set above. In no event will American Eagle, the American Eagle distributor/dealer, or any company affiliated with American Eagle be liable for business interruptions, costs of delay, or for any special, indirect, incidental, or consequential costs or damages. Such costs may include, but are not limited to, loss of time, loss of revenue, loss of use, wages, salaries, commissions, lodging, meals, towing, hydraulic fluid, or any other incidental cost.

All products purchased by American Eagle from outside vendors shall be covered by the warranty offered by that respective manufacturer only. American Eagle does not participate in, or obligate itself to, any such warranty.

American Eagle reserves the right to make changes in design or improvement upon its products without imposing upon itself the same upon its products theretofore manufactured.

This warranty will apply to all American Eagle Drawer Sets and Compressed Air Systems shipped from American Eagle's factory after July 1, 2005. The warranty is for the use of the original owner only and is not transferable without prior written permission from American Eagle.

THIS WARRANTY IS EXPRESSLY IN LIEU OF ANY OTHER WARRANTIES, EXPRESS OR IMPLIED, INCLUDING ANY WARRANTY OF MERCHANTABILITY OR FITNESS FOR A PARTICULAR PURPOSE. REMEDIES UNDER THIS WARRANTY ARE LIMITED TO THE PROVISION OF MATERIAL AND SERVICES, AS SPECIFIED HEREIN. AMERICAN EAGLE INDUSTRIES, INC. IS NOT RESPONSIBLE FOR INCIDENTAL OR CONSEQUENTIAL DAMAGES.

Revision Date: May 2011

Document Number: 37042