

# AMERICAN EAGLE COMPRESSORS

---

## Specifications for Model SHD-60AF Hydraulic Drive Air Compressor

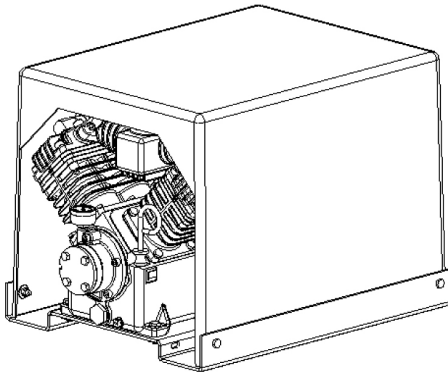

These units include the American Eagle single-stage reciprocating pump, which is directly attached to the hydraulic motor (no pulleys and belts), a hydraulic oil cooler, 12V. fan, valve block, and fiberglass cover.

- Imbedded air filter
- Cast iron crankcase casting
- Cast aluminum cylinder heads
- Pressure lubrication system
- Pulsation manifold tank
- Pressure switch and check valve
- All steel plumbing with J.I.C. fittings
- Optional 11-gallon hydraulic reservoir

**Model:** American Eagle SHD-60AF Hydraulic Drive Air Compressor.

**Max Pressure:** 150 PSI

**Output Capacity:** 30 CFM at 100 PSI

**Hyd. Power Req:** 10 GPM at 1800 PSI

**Displacement:** 60 CID, 4-cylinder, single stage

**Compressor System:** The compressor has a 2-3/4" bore and 2-1/2" stroke. The hydraulic porting is 1/2" minimum on the inlet and 3/4" minimum on the outlet through a 12 volt solenoid on/off valve block. All internal plumbing is steel tubing with JIC fittings. A 3/4" N.P.T. is on the air outlet with a 3/4" one way check valve. The compressor is equipped with a built-in 12-volt electric fan and oil cooler for the main system hydraulic oil. It has stainless steel reed valves, pressure lubrication system and a pulsation manifold tank.

An air pressure sensing switch shall be installed in the outlet air line and be connected to an air unloader valve so as to allow the compressor to unload when proper operating pressures are obtained.

**Electrical Control:** 12 VDC @ 1-1/2 amps

**Weight:** 175 pounds (without reservoir)  
240 pounds (with reservoir)

**Dimensions:** 26" L x 18" H x 18" W (without reservoir)  
31-1/2" L x 24-1/2" H x 18-1/2" W (with reservoir)

**Pump:** Model V480 Pump

- Single-Stage Four-Cylinder
- 2-3/4" Bore x 2-1/2" Stroke
- Lubrication - Pressure
- Discharge - 1/2" NPT
- Flow - 16 to 30 CFM
- HP Required - 5, 7-1/2, 10
- Speeds - 800 to 1300 RPM
- Weight - 89 lbs

# AMERICAN EAGLE COMPRESSORS

---

## Specifications for Model SHD-60AF Hydraulic Drive Air Compressor

- Overall Description:** The compressor shall be on American Eagle Accessories Group Model SHD-60AF single-stage, reciprocating compressor. The compressor shall be hydraulically driven. The compressor system including cooling and plumbing shall be mounting on a powder-coated steel base and contained in a fiberglass enclosure.
- Compressor System:** The compressor shall be driven by a gear type hydraulic motor having a displacement of 1.77 cubic inches per revolution capable of driving the compressor at 1,250 RPM with 10 GPM @ 1800 PSI through a control valve block containing the on/off, 12 VDC solenoid valve and a 0 to 3000 PSI adjustable main system pressure relief valve. Properly sized steel tubing must be used from the control block through the motor and it shall be attached to a hydraulic oil cooler with a cooling capacity of 300 BTU per minute with 10 GPM of 200 degree oil. The cooling shall be provided by a 12 VDC electric motor directly attached to the cooler providing 870 CFM airflow across the cooler fins. The hydraulic motor shall be coupled directly to the compressor with a Lovejoy type coupler and a high impact spider insert. An air pressure sensing switch shall be installed in the outlet air line and be connected to a air unloader valve so as to allow the compressor to unload when proper operating pressures are obtained. A powder coated base plate attaching the compressor, hydraulic motor mount, hydraulic valve block and fiberglass cover is required to complete the system.
- Compressor Pump:** The compressor shall be an American Eagle Accessories Model V-480 single-stage, 4-cylinder, reciprocating, piston type design, with a capacity of 30 CFM at 100 PSI and a pressure range of 0 to 150 PSI. The crankcase, end bearing plates and cylinders are to be made of cast iron material. The compressor pump shall have high temperature aluminum 2-3/4" pistons incorporating the three-ring design and drilled cast aluminum rod assemblies. A semi balanced crankshaft with 2-1/2" of stroke, polished steel roller type bearings each end and must be drilled with oil journals to incorporate the gear type pressure lubrication oil pump system connection. The oil pump system shall be incorporated into the rear bearing housing and aligned with the crankshaft assembly. The compressor pump shall have reed valve assemblies made of high tensile stainless steel which are installed between the cylinder and head assembly that has a embedded air filter with a inner and outer sponge type filter designed into the casting. The compressor shall be painted black using heat sensitive paint.
- Dimensions:** The compressor shall be 26"L x 18"H x 18"W (without hydraulic reservoir) or 31-1/2"L x 24-1/2"H x 18-1/2"W (with 11 gallon hydraulic reservoir).
- Weight:** The compressor shall be approximately 175-pounds (without hydraulic reservoir) or 240-pounds (with hydraulic reservoir).
- Air Reservoir:** The air reservoir shall have a minimum of 22-gallon capacity and be ASME certified with proper placard. Mounting brackets shall be provided to fit the chassis specified with all the proper hardware and fittings kits. Tanks shall be prime painted to prevent rusting.
- Air Filter/Lubricator/Regulator:** An inline air filter lubricator regulator (FLR) with a minimum of 1/2" plumbing shall be provided. The filter shall be equipped with a moisture drain valve. The lubricator shall have a 1-pint capacity and be directly coupled inline with the regulator. Mounting shall be made with a properly secured bracket to prevent vibration or breakage.
- Air Hose Reel:** A minimum of one hose reel with 50' of 1/2" ID hose with end cap shall be provided. Retraction shall be done by a heavy-duty spring rewind system through a four-point roller guide. The guide may be connected either to the reel or attached to the vehicle body and shall have a spring latching mechanism to prevent accidental retraction of the hose.
- Warranty:** The manufacturer shall provide a limited warranty of materials and workmanship for a period of one year from the date of delivery.